

2024 EDITION

DISTRIBUTED BY

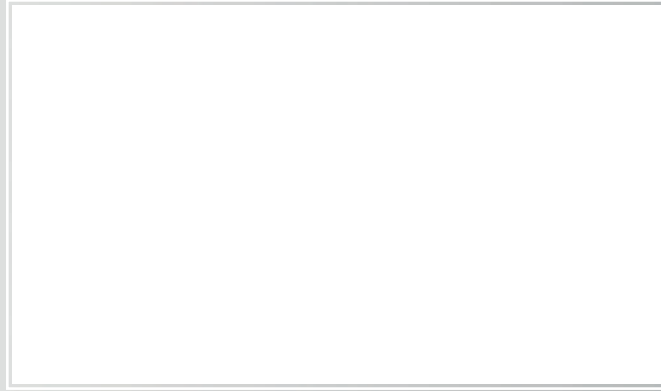

INDUSTRIAL - OTR
TIRES

petlas

Headquarters - Factory

Petlas Tire Industry and Trade
Kindam Mahallesi Ankara - Kayseri Caddesi
No: 2/1 Kırşehir / TURKEY
T: +90 386 252 65 50 • F: +90 386 252 65 70

Int. Sales & Marketing

Petlas Tire Industry and Trade Ako Kule
Söğütözü Mh. 2178. Cd. No: 6
06530 Ankara/TURKEY
T. +90 312 309 30 30 • F: +90 312 309 22 66

Petlas Tire USA

1111 E. Lincolnway STE 205
Cheyenne, WY 82001 USA

www.petlas.com

MADE IN TÜRKİYE

petlas
TRACK OF TRUST

Petlas IND-OTR tires are characterized by quality workmanship, leading edge technology, unique tread designs and excellent performance offering perfect mix of quality and value.

Our success depends on exceeding the expectations of our customers and standing behind everything we do.

Our aim is to build long term relationships with our customers by providing excellent service, quality and delivering our promises.

NOTICES & DISCLAIMER

- For load capacity and inflating pressure figures on different speed rates, please consult the producer company.
- Our company is entitled to change any information in this brochure without prior notice. This brochure overrides any previous documents.
- All figures are for reference and our company cannot be deemed responsible for printing errors.
- The visual content of this brochure is only representative. To find the compatible tire for your vehicle, please refer to the vehicle service or authorized tire dealer.

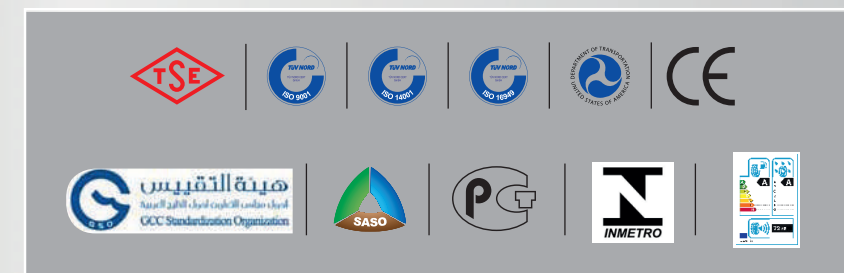

petlas
TRACK OF TRUST

CONTENTS

Page 3 Range of Petlas Ind-Otr Tires

Page 4 Petlas Ind-Otr Tires by Size

Page 10 General Information

RADIAL TIRES	INDUSTRIAL TRACTION	PAGE
	PtxND31 (R-4)	12
PtxND33 (R-4)	13	
GRADER		
PtxL42 (G-2)	14	
LOADER / GRADER		
PtxL43 (L-3/G3)	15	
EARTHMOVER / LOADER		
PtxL31 (E-3/L-3)	16	
LOADER		
PtxL41 (L-3)	17	
PtxL51 (L-3)	18	
FORKLIFT		
HL-10	19	
HL-30 (PNEUMATIC)	20	
HL-40	21	
SOLID ST (SOLID)	22	
COMPACTOR		
FLT-2 (R-3)	23	
PC-1 (C-1)	24	
SKID STEER		
IND-15 (R-4)	25	
IND-35	26	

INDUSTRIAL / INDUSTRIAL TRACTION	PAGE
TD-45 (F-3)	27
IND-30 (R-4)	28
IND-15 (R-4)	29
IND-25 (R-4)	30
TA-60 (I-3)	31
IND-5 (R-1)	32
PL-2 (L-2)	33
EXCAVATOR	
NB-38 (E-3)	34
GRADER	
PG-200 (G-2)	35
PG-300 (G-2)	36
EARTHMOVER	
NB-57 (E-3)	37
NB-60 (E-3)	38
LOADER	
NB-57 (L-3)	39
NB-60 (L-3)	40
NB-70 (L-3)	41
NB-70 (L-4)	42
PORT APPLICATION	
C+CARRIER (L-4)	43
C+CARRIER SMOOTH (L-4S)	44

It's hard to be in your shoes.

That is why we produce the best off road tires for you.



Strong, durable, affordable off road tires.

export@petlas.com • www.petlas.com

petlas
TRACK OF TRUST

RANGE OF PETLAS IND-OTR TIRES

RADIAL INDUSTRIAL TRACTION



PtxND31 (R-4) PtxND33 (R-4)

GRADER RADIAL



PtxL42 (G-2)

LOADER / GRADER RADIAL



PtxL43 (L-3/G-3)

EARTHMOVER / LOADER RADIAL



PtxL31 (E-3/L-3)

LOADER RADIAL



PtxL41 (L-3) PtxL51 (L-3)

FORKLIFT



HL-10 HL-30 (PNEUMATIC) HL-40 SOLID ST (SOLID)

COMPACTOR



FLT-2 (R-3) PC-1 (C-1)

SKID STEER



IND-15 (R-4) IND-35

INDUSTRIAL



TD-45 (F-3)

INDUSTRIAL TRACTION



IND-30 (R-4) IND-15 (R-4) IND-25 (R-4) TA-60 (I-3) IND-5 (R-1) PL-2 (L-2)

EXCAVATOR



NB-38 (E-3)

GRADER



PG-200 (G-2) PG-300 (G-2)

EARTHMOVER



NB-57 (E-3) NB-60 (E-3)

LOADER



NB-57 (L-3) NB-60 (L-3) NB-70 (L-3) NB-70 (L-4)

PORT APPLICATION



C+CARRIER (L-4) C+CARRIER SMOOTH (L-4S)

PETLAS TIRES BY SIZE

RADIAL INDUSTRIAL TRACTION PtXND31 (R-4)



340/80R 18 (12.5/80R 18)
400/70R 20
405/70R 20 (16.0/70R 20)
460/70R 24 (17.5LR 24)
440/80R 28 (16.9R 28)
340/80R 20 (12.5R 20)
480/80R 26 (18.4R 26)

EARTHMOVER LOADER RADIAL PtXL31 (E-3/L-3)



17.5R 25
20.5R 25
23.5R 25
26.5R 25
29.5R 25

RADIAL INDUSTRIAL TRACTION PtXND33 (R-4)



460/70 R24 (17.5LR24)

LOADER RADIAL PtXL41 (L-3)



17.5R 25
20.5R 25
23.5R 25
26.5R 25
29.5R 25

GRADER RADIAL PtXL42 (G-2)



14.00R 24

LOADER RADIAL PtXL51 (L-3)



20.5R 25
23.5R 25
26.5R 25
29.5R 25

LOADER GRADER RADIAL PtXL43 (L-3/G-3)



17.5R 25

FORKLIFT HL-10



7.00-12 23x5-13
27x10-12 4.00-8
8.15-15 5.00-8
8.25-15 18x7-8
6.00-9
21x8-9
6.50-10
23x9-10



PETLAS TIRES BY SIZE



**FORKLIFT HL-30
(PNEUMATIC)**

16x6-8 7.00-12
4.00-8 27x10-12
5.00-8 23x5-(13)
18x7-8 7.50-15
21x8-9 8.15-15
6.00-9 250-15
6.50-10 300-15
23x9-10



**COMPACTOR
PC-1 (**C1)**

11.00-20
13.0/80R 20



**FORKLIFT
HL-40**

6.00-9
6.50-10
7.00-12
8.15-15
8.25-15



**SKID STEER
IND-15 (R-4)**

10-16.5 NHS
12-16.5 NHS



**FORKLIFT
SOLID ST (SOLID)**

6.50-10
23x10-12⁽³⁾



**SKID STEER
IND-35**

10-16.5
12-16.5



**COMPACTOR
FLT-2 (R-3)**

23.1-26



**INDUSTRIAL
TD-45 (F-3)**

11L-16 SL

PETLAS TIRES BY SIZE



**INDUSTRIAL TRACTION
IND-30 (R-4)**

16.0/70-20

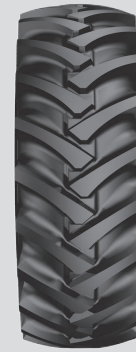

**INDUSTRIAL TRACTION
IND-5 (L-2)**

16.9-30
18.4-26



**INDUSTRIAL TRACTION
IND-15 (R-4)**

10.0/75-15.3
11.5/80-15.3
10.5/80-18
280/80-18
16.0/70-20
405/70-20
14.5-20
16.0/70-24
405/70-24
480/80-26
23.1-26



**INDUSTRIAL TRACTION
PL-2 (L-2)**

15.5-25



**INDUSTRIAL TRACTION
IND-25 (R-4)**

12.5/80-18	16.5/85-24
340/80-18	16.5/85-24
14.5-20	19.5L-24
14.5-20	16.9-28
16.0/70-20	16.9-28
16.0/70-20	16.9-28
405/70-20	440/80-28
16.9-24	18.4-26
16.9-24	18.4-26
16.0/70-24	18.4-26
405/70-24	480/80-26
440/80-24	



**EXCAVATOR
NB-38 (E-3)**

7.50-20
9.00-20
10.00-20



**GRADER
PG-200 (G-2)**

13.00-24
14.00-24



**INDUSTRIAL TRACTION
TA-60 (I-3)**

15.5/80-24



**GRADER
PG-300 (G-2)**

16.00-24



PETLAS TIRES BY SIZE

EARTHMOVER NB-57 (E-3)

14.00-24



LOADER NB-70 (L-3)

15.5-25
17.5-25
20.5-25
23.5-25
26.5-25
29.5-25



EARTHMOVER NB-60 (E-3)

16.00-25
18.00-25



LOADER NB-70 (L-4)

26.5-25
29.5-25



LOADER NB-57 (L-3)

17.5-25
20.5-25
23.5-25



PORT APPLICATION C+CARRIER (L-4)

18.00-25



LOADER NB-60 (L-3)

17.5-25
20.5-25
23.5-25
26.5-25
29.5-25



PORT APPLICATION C+CARRIER SMOOTH (L-4S)

18.00-25



A) Bias

- 1.Brand
2. Pattern Name
3. Tire Size
4. Ply Rating
5. Load/Speed Index
6. ECE R-106 Approval Code
7. TL/TT
8. Max. Bead Seating Pressure
9. Rotation
10. Maximum Load (Inflation Pressure)
11. Construction Information
12. DOT Symbol - Week Code



B) Radial

1. Brand
2. Pattern Name
3. Tire Size
4. Tractor/Grader Type
5. TRA Code
6. Star Marking
7. Security Information
8. Construction Information
9. Load / Speed Index
10. DOT Symbol - Week Code

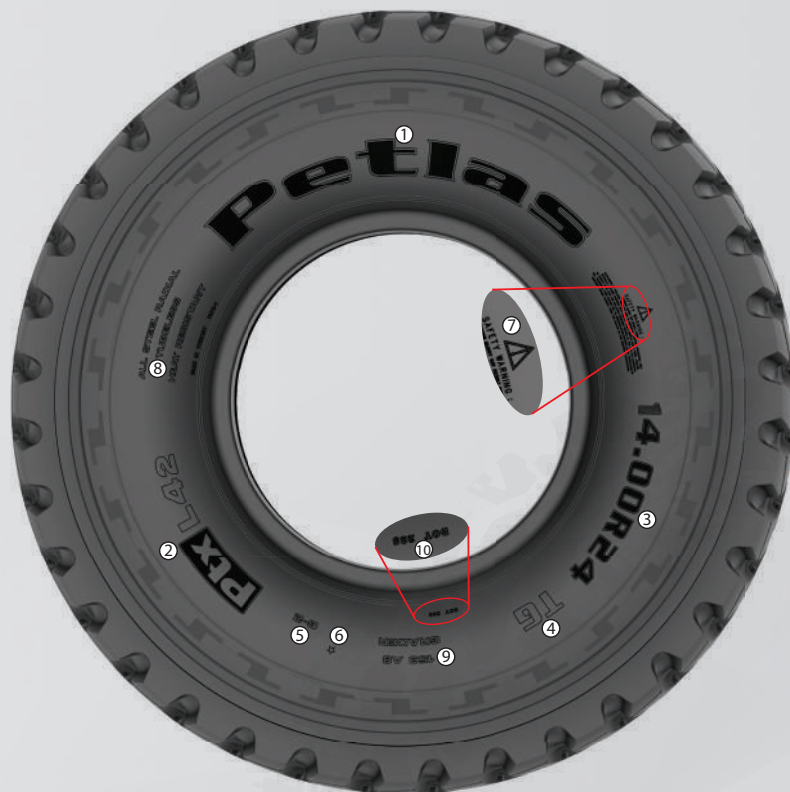

UNIT CONVERSION TABLE

UNIT CONVERSION TABLE

Unit	Abbreviation	Conversion Coefficient	Abbreviation	Unit	Abbreviation	Conversion Coefficient
Length						
inch	in	x 0,0254	= m	(Metre)	x 39,37	= in
foot	ft	x 0,3048	= m	(Metre)	x 3,281	= ft
yard	yd	x 0,9144	= m	(Metre)	x 1,0936	= yd
mile	ml	x 1,6093	= km	(Kilometre)	x 0,6214	= mile
Load						
Pound	lb	x 0,4536	= kg	(Kilogramme)	x 2,205	= lb
Long Ton (U.K) 2240 lbs	lg ton	x 1,016	=T	(Metric Tonne)	x 0,984	= lg ton
Short Ton (U.S) 2000 lbs	sh ton	x 0,907	=T	(Metric Tonne)	x 1,103	= sh ton
Pressure						
Kilo - Pascal	kPa	x 0,01	= bar	(Bar)	x 100	= kPa
Atmosphere (at sea level)	atm	x 0,986	= bar	(Bar)	x 1,014	= atm
Pound/Square inch	ibf/in ² (psi)	x 0,0703	= kg/cnf	(Kilogramme/cm ³)	x 14,22	ibf/in ² (psi)
Pound/Square inch	ibf/in ² (psi)	x 0,069	= bar	(Bar)	x 14,513	ibf/in ² (psi)
Pound/Square inch	ibf/in ² (psi)	x 0,068	= atm	(Atmosphere)	x 14,7	ibf/in ² (psi)
Pound/Square inch	ibf/in ² (psi)	x 6,895	= kPa	(Kilo Pascal)	x 0,145	ibf/in ² (psi)
Capacity						
Cubic Foot	ft ³	x 0,02832	= m ³	(Cubic Metre)	x 35,31	= ft ³
Cubic Yard	yd ³	x 0,7646	= m ³	(Cubic Metre)	x 1,308	= yd ³
Cycle Strength						
Pound Foot	lb ft	x 0,1383	= kgm	(Kilogramme Metre)	x 7,233	= lb ft
Kilogramme Metre	kgm	x 9,81	= Nm	(Newton Metre)	x 0,102	= m kg

TIRE DEFINITION CODE

Service		Tread Types	
Code	Type Of Service	Code	Tread Type
C	Compactor	C - 1	Smooth
		C - 2	Grooved
E	Earthmover	E - 1	Rib
		E - 2	Traction
		E - 3	Rock
		E - 4	Rock Deep Tread
		E - 7	Flotation
G	Grader	G - 1	Rib
		G - 2	Traction
		G - 3	Rock
L	Loader and Dozer	L - 2	Traction
		L - 3	Rock
		L - 3S	Smooth
		L - 4	Rock Deep Tread
		L - 4S	Smooth Deep Tread
		L - 5	Rock Extra Deep Tread
L - 5S	Smooth Extra Deep Tread		



LOAD INDEX

LI	kg	LI	kg	LI	kg	LI	kg	LI	kg
120	1400	150	3350	180	8000	210	19000	240	45000
121	1450	151	3450	181	8250	211	19500	241	46250
122	1500	152	3550	182	8500	212	20000	242	47500
123	1550	153	3650	183	8750	213	20600	243	48750
124	1600	154	3750	184	9000	214	21200	244	50000
125	1650	155	3875	185	9250	215	21800	245	51500
126	1700	156	4000	186	9500	216	22400	246	53000
127	1750	157	4125	187	9750	217	23000	247	54500
128	1800	158	4250	188	10000	218	23600	248	56000
129	1850	159	4375	189	10300	219	24300	249	58000
130	1900	160	4500	190	10600	220	25000	250	60000
131	1950	161	4625	191	10900	221	25750	251	61500
132	2000	162	4750	192	11200	222	26500	252	63000
133	2060	163	4875	193	11500	223	27250	253	65000
134	2120	164	5000	194	11800	224	28000	254	67000
135	2180	165	5150	195	12150	225	29000	255	69000
136	2240	166	5300	196	12500	226	30000	256	71000
137	2300	167	5450	197	12850	227	30750	257	73000
138	2360	168	5600	198	13200	228	31500	258	75000
139	2430	169	5800	199	13600	229	32500	259	77500
140	2500	170	6000	200	14000	230	33500	260	80000
141	2575	171	6150	201	14500	231	34500	261	82500
142	2650	172	6300	202	15000	232	35500	262	85000
143	2725	173	6500	203	15500	233	36500	263	87500
144	2800	174	6700	204	16000	234	37500	264	90000
145	2900	175	6900	205	16500	235	38750	265	92500
146	3000	176	7100	206	17000	236	40000	266	95000
147	3075	177	7300	207	17500	237	41250	267	97500
148	3150	178	7500	208	18000	238	42250	268	100000
149	3250	179	7750	209	18500	239	43750	269	103000

(LI) : Load Index

SPEED CATEGORY

Symbol	A2	A3	A4	A5	A6	A8	B	C	D	E	F	G
Speed km/h	10	15	20	25	30	40	50	60	65	70	80	90

Sample Tire Marking

16.00 - 25 NB60 E3 32 PR TL 177 B

(This tire can carry 7300 kg load at the speed of 50 km/h.)



Go Forth

*The most demanding job on earth
requires the most durable tires in the world.
Go forth with Petlas **OTR** tires.*

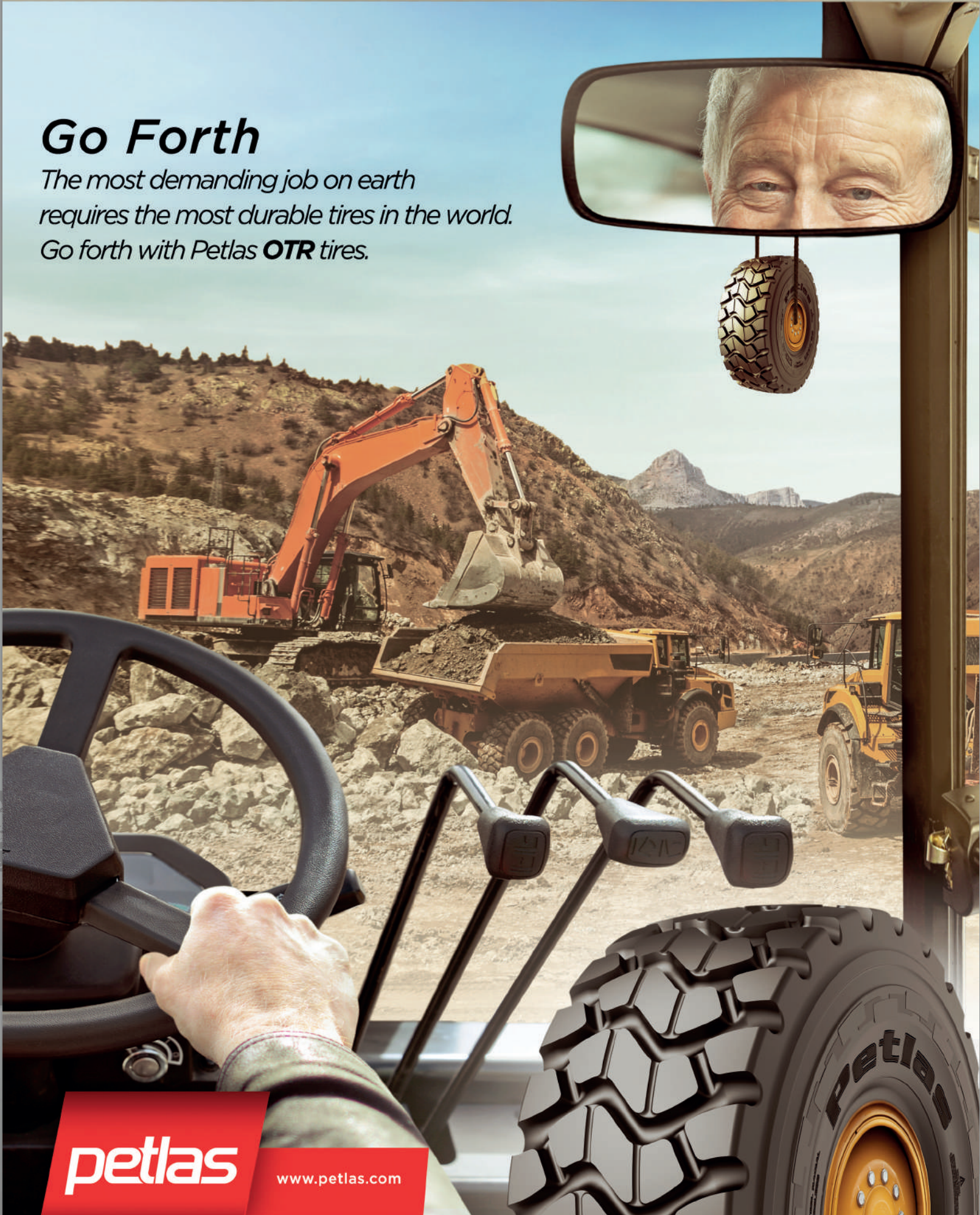

petlas

www.petlas.com

PtxND31 (R-4)

PtxND31 (R-4) tire has strong radial casing and steel belted construction. It is developed for construction equipment to be used in the areas of agriculture and construction. The directional tread pattern provides excellent traction, longevity, resistance to damage and high carrying capacity.

PtxND31 (R-4) is the right response to agro-industrial heavy-duty needs. It is suitable for all digging and loading operations on vehicles such as telehandlers, compact loaders and backhoe loaders.

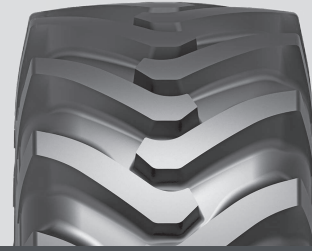

TIRE SIZE	TT/TL	LOAD INDEX	SPEED SYMBOL	RIM		INFLATED DIMENSIONS (NO LOAD)		INFLATED DIMENSIONS (W/LOAD)		TREAD DEPTH (MM)	INFLATING PRESSURE (psi)	LOAD CAPACITY PER TIRE (KG)				
				RECOM. (INCHES)	PERMITTED (INCHES)	OUTER DIAMETER (MM)	SECTION WIDTH (MM)	STATIC LOADED RADIUS (MM)	DYNAMIC RADIUS CIRCLE (MM)			Speed (KM/H)				
												10	25	30	40	50
340/80R18 (12.5/80R18)	TL	143	A8/B	11	W10, 11SDC, W11, 12, 12SDC	995	345	446	2975	30	58	3405	3025	2915	2725	2725
340/80 R20 (12.5 R20)	TL	138	A8/B	11	12.00, 11SDC, 12SDC W10, W11	1052	343	477	3145	29	46	2950	2570	2455	2360	2150
340/80 R20 (12.5 R20)	TL	144	A8/B	11	12.00, 11SDC, 12SDC W10, W11	1052	343	477	3145	29	58	3500	3050	2910	2800	2550
400/70 R20	TL	149	A8/B	13	12SDC, 13SDC, 14	1068	404	480	3194	30	58	4065	3610	3480	3250	3250
405/70 R20 (16.0/70R 20)	TL	149	A8/B	13	12SDC, 13SDC, 14	1070	414	480	3200	30	58	4065	3610	3480	3250	3250
460/70 R24 (17.5LR24)	TL	159	A8/B	DW15L	DW14L DW16L	1251	453	562	3740	36	58	5470	4855	4680	4375	4375
440/80R28 (16.9R28)	TL	156	A8/B	DW14L	DW13, DW13L DW15L	1415	441	636	4215	35	46	5000	4440	4280	4000	4000
480/80 R26 (18.4 R26)	TL	167	A8/B	DW15L	DW16L	1428	479	645	4253	35	58	6810	5940	5670	5450	4960



PtxND33 (R-4)

PtxND33 (R-4) is developed and designed to offer perfect traction and long life for compact industrial vehicles such as compact loaders, backhoe loaders and telehandlers. Deep and wide lugs are carefully located on the tread to ensure perfect traction on hard or soft terrains. The wide tread profile provides a balanced feel on every condition and increases the tire's service life by avoiding irregular wear. Reinforced sidewalls offer maximum resistance against cuts and puncture while the steel belts under the tread improve the tire's durability and load capacity

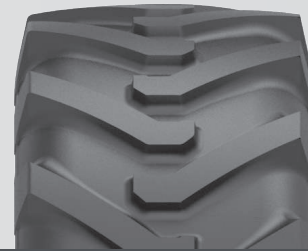

TIRE SIZE	TT/TL	LOAD INDEX	SPEED SYMBOL	RIM		INFLATED DIMENSIONS (NO LOAD)		INFLATED DIMENSIONS (W/LOAD)		TREAD DEPTH (MM)	INFLATING PRESSURE (psi)	LOAD CAPACITY PER TIRE (KG)				
				RECOM. (INCHES)	PERMITTED (INCHES)	OUTER DIAMETER (MM)	SECTION WIDTH (MM)	STATIC LOADED RADIUS (MM)	DYNAMIC RADIUS CIRCLE (MM)			Speed (KM/H)				
												10	25	30	40	50
460/70 R24 (17.5LR24)	TL	159/159	A8/B	DW14L, DW16L	DW15L	1251	453	562	3740	25	46	5470	4855	4680	4375	4375



PtxL42 (G-2)

PtxL42 (G-2) is an all steel radial tire that promises resistance to tears and wears in worksites and on challenging roads. Specially formulated tread compound and all steel carcass structure of PtxL42 (G-2) offer longevity. The non-directional pattern design delivers outstanding traction and grip in demanding conditions.

PtxL42 (G-2) is designed especially for grader applications.

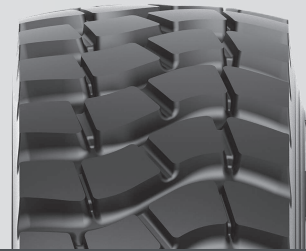

TIRE SIZE	STAR RATING	TT/TL	LOAD INDEX	SPEED SYMBOL	RIM		INFLATED DIMENSIONS (NO LOAD)		INFLATED DIMENSIONS (W/LOAD)		TREAD DEPTH (MM)	INFLATING PRESSURE (psi)	LOAD CAPACITY PER TIRE (KG)			
					RECOM. (INCHES)	PERMITTED (INCHES)	OUTER DIAMETER (MM)	SECTION WIDTH (MM)	STATIC LOADED RADIUS (MM)	DYNAMIC RADIUS CIRCLE (MM)			Speed (KM/H)			
													20	30	40	50
14.00 R24	★	TL	153	A8	8.00 TG SDC	9.00/1.5 (DC); 10.00/VA SDC	1348	364	608	3909	26	54	3650	3650	3650	3322



PtxL43 (L-3/G-3)

PtxL43 (L-3/G-3) is an all steel radial tire suitable for loader and grader applications. Delivers optimized performance on all grounds. The compound and the aggressive design of the tread pattern enhance handling throughout the tire's exceptional service life. Offers outstanding resistance against cuts and wears. PtxL43 is the ultimate choice when traction is the priority.

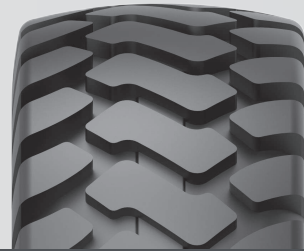
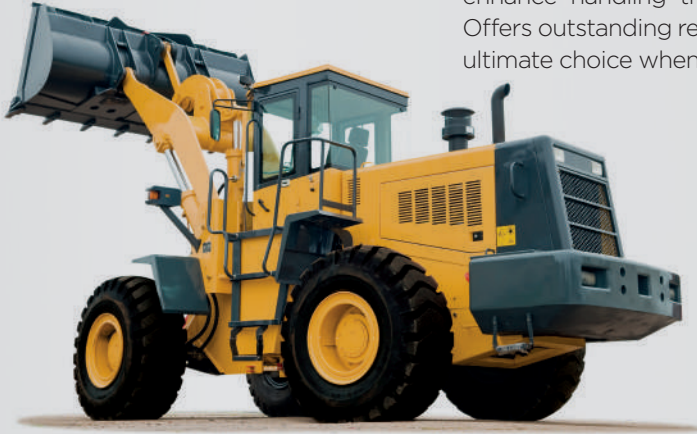

TIRE SIZE	STAR RATING	TT/ TL	LOAD INDEX	SPEED SYMBOL	RIM		INFLATED DIMENSIONS (NO LOAD)		INFLATED DIMENSIONS (W/LOAD)		TREAD DEPTH (MM)	LOAD CAPACITY PER TIRE (KG)													
					RECOM. (INCHES)	PERMITTED (INCHES)	OUTER DIAMETER (MM)	SECTION WIDTH (MM)	DYNAMIC RADIUS CIRCLE (MM)	STATIC LOADED RADIUS (MM)		INFLATING PRESSURE bar/psi	2,00	2,25	2,50	2,75	3,00	3,25	3,50	3,75	4,00	4,25	4,50	4,75	5,00
17.5R 25	★	TL	176 / 153	A2/ A8	14.00 / 1.5	14.00 / 1.3 (DC)	1345	445	4035	595	26	LOADER (L-3)	3650	4000	4250	5625	4850	5300	5600	5800	6000	6150	6500	6700	7100
												GRADER (G-3)	2575	2900	3075	3350	3650	-	-	-	-	-	-	-	-



PtxL31 (E-3/L-3)

PtxL31 (L-3 / E-3) is an all steel radial OTR tire that offers ultimate resistance to all kind of damage and is designed to be used on loaders and articulated trucks.

Demonstrates efficient self-cleaning feature thanks to its special grooving geometry. Inter-located blocks keep their integrity on all kind of grounds. Specially designed tread compound minimizes cuts and punctures on semi rough ground conditions while simultaneously reducing heat generation to boost service life and improve wear performance.



TIRE SIZE	STAR RATING	TT/ TL	LOAD INDEX	SPEED SYMBOL	RIM		INFLATED DIMENSIONS (NO LOAD)		INFLATED DIMENSIONS (W/ LOAD)		TREAD DEPTH (MM)	Speed (KM/H)	LOAD CAPACITY PER TIRE (KG)				
					RECOM. (INCHES)	PERMITTED (INCHES)	OUTER DIAMETER (MM)	SECTION WIDTH (MM)	STATIC LOADED RADIUS (MM)	DYNAMIC RADIUS CIRCLE (MM)			INFLATING PRESSURE bar/psi	3,5 / 51	4 / 58	4,5 / 65	5 / 73
17.5R 25	★★	TL	182/167	A2/B	14.00/1.5	14.00/1.3 (DC) 13.00/1.4 (DC)	1348	442	583	4025	29	10 km/h **	6.250	6.700	7.350	7.925	8.500
												50 km/h ***	4.470	5.000	5.450	-	-
20.5R 25	★★	TL	193/177	A2/B	17.00/2.0	17.00/2.0 IF	1484	550	652	4408	35	10 km/h **	8.450	9.200	9.950	10.700	11.500
												50 km/h ***	6.000	6.700	7.300	-	-
23.5R 25	★★	TL	201/185	A2/B	19.50/2.5	19.50/2.5 IF	1611	630	711	4804	39	10 km/h **	10.650	11.750	12.750	13.600	14.500
												50 km/h ***	7.500	8.500	9.250	-	-
26.5R 25	★★	TL	209/193	A2/B	22.00/3.0	22.00/3.0 IF	1755	705	772	5195	44	10 km/h **	13.600	15.000	16.150	17.350	18.500
												50 km/h ***	9.500	10.500	11.500	-	-
29.5R 25	★★	TL	216/200	A2/B	25.00/3.5	25.00/3.5 IF	1861	776	811	5546	44	10 km/h **	16.450	18.150	19.550	21.000	22.400
												50 km/h ***	11.500	12.750	14.000	-	-

** In loader applications the tire have to run in one way direction, at 10 km/h speed, max. 76m (250 feet) with load.

*** In earthmover applications the tire have to run in one way direction, at 50 km/h speed max. 4km (2,5 mile) with load.



PtxL41 (L-3)

PtxL41(L-3) is an all steel radial OTR tire resistant to all kind of damages, designed to be used on loader applications.

Demonstrates efficient self-cleaning feature thanks to its special grooving geometry. Inter-connected blocks keep their integrity on all kind of grounds. Tread compound is specifically designed to work perfectly on semi-rough ground conditions and tough terrains as well, providing excellent wear performance and high resistance against cuts, chips and heat on challenging operating conditions.



TIRE SIZE	STAR RATING	TT/ TL	LOAD INDEX	SPEED SYMBOL	RIM		INFLATED DIMENSIONS (NO LOAD)		INFLATED DIMENSIONS (W/LOAD)		TREAD DEPTH (MM)	Speed (KM/H)	LOAD CAPACITY PER TIRE (KG)				
					RECOM. (INCHES)	PERMITTED (INCHES)	OUTER DIAMETER (MM)	SECTION WIDTH (MM)	STATIC LOADED RADIUS (MM)	DYNAMIC RADIUS CIRCLE (MM)			INFLATING PRESSURE bar/psi	3,5 / 51	4 / 58	4,5 / 65	5 / 73
17.5 R25	★★	TL	182	A2	14.00/1,5	14.00/1,3 (DC) 13.00/1,4 (DC)	1348	442	583	4025	29	10 km/h **	6.250	6.700	7.350	7.925	8.500
20.5 R25	★★	TL	193	A2	17.00/2,0	17.00/2,0 IF	1484	550	652	4408	35	10 km/h **	8.450	9.200	9.950	10.700	11.500
23.5 R25	★★	TL	201	A2	19.50/2,5	19.50/2,5 IF	1611	630	711	4804	39	10 km/h **	10.650	11.750	12.750	13.600	14.500
26.5 R25	★★	TL	209	A2	22.00/3,0	22.00/3,0 IF	1755	705	772	5195	44	10 km/h **	13.600	15.000	16.150	17.350	18.500
29.5 R25	★★	TL	216	A2	25.00/3,5	25.00/3,5 IF	1861	776	811	5546	44	10 km/h **	16.450	18.150	19.550	21.000	22.400

TIRE SIZE	STAR RATING	TT/ TL	LOAD INDEX	SPEED SYMBOL	RIM		INFLATED DIMENSIONS (NO LOAD)		INFLATED DIMENSIONS (W/LOAD)		TREAD DEPTH (MM)	LOAD CAPACITY PER TIRE (KG)													
					RECOM. (INCHES)	PERMITTED (INCHES)	OUTER DIAMETER (MM)	SECTION WIDTH (MM)	DYNAMIC RADIUS CIRCLE (MM)	STATIC LOADED RADIUS (MM)		INFLATING PRESSURE (psi)	2,00	2,25	2,50	2,75	3,00	3,25	3,50	3,75	4,00	4,25	4,50	4,75	5,00
17.5R 25	★	TL	176 / 153	A2/ A8	14.00 / 1,5	14.00 / 1,3 (DC)	1345	445	4035	595	26	LOADER (L-3)	3650	4000	4250	5625	4850	5300	5600	5800	6000	6150	6500	6700	7100
												GRADER (G-3)	2575	2900	3075	3350	3650	-	-	-	-	-	-	-	-



PtxL51 (L-3)

PtxL51(L-3) is an all steel radial tire designed to be used on loader applications.

Demonstrates efficient self-cleaning feature thanks to its special grooving geometry. Inter-connected blocks keep their integrity on all kind of grounds. Offers outstanding cut-chip and wear resistance for a variety of harsh operating conditions thanks to its special compound that is durable towards extremely tough terrains.



TIRE SIZE	STAR RATING	TT/ TL	LOAD INDEX	SPEED SYMBOL	RIM		INFLATED DIMENSIONS (NO LOAD)		INFLATED DIMENSIONS (W/ LOAD)		TREAD DEPTH (MM)	Speed (KM/H)	LOAD CAPACITY PER TIRE (KG)				
					RECOM. (INCHES)	PERMITTED (INCHES)	OUTER DIAMETER (MM)	SECTION WIDTH (MM)	STATIC LOADED RADIUS (MM)	DYNAMIC RADIUS CIRCLE (MM)			INFLATING PRESSURE bar/psi	3.5 / 51	4 / 58	4.5 / 65	5 / 73
20.5 R25	★★	TL	193	A2	17.00/2.0	17.00/2.0 IF	1484	550	652	4408	35	10 km/h **	8.450	9.200	9.950	10.700	11.500
23.5 R25	★★	TL	201	A2	19.50/2.5	19.50/2.5 IF	1611	630	711	4804	39	10 km/h **	10.650	11.750	12.750	13.600	14.500
26.5 R25	★★	TL	209	A2	22.00/3.0	22.00/3.0 IF	1755	705	772	5195	44	10 km/h **	13.600	15.000	16.150	17.350	18.500
29.5 R25	★★	TL	216	A2	25.00/3.5	25.00/3.5 IF	1861	776	811	5546	44	10 km/h **	16.450	18.150	19.550	21.000	22.400



HL-10

HL-10 is designed for general purpose tasks. Its strong carcass structure and bead construction provide high performance and durability against impacts.



TIRE SIZE	PR	TT/TL	LOAD INDEX	SPEED SYMBOL	INFLATING PRESSURE (psi)	RIM		INFLATED DIMENSIONS (NO LOAD)		LOAD CAPACITY PER TIRE (KG)
						RECOM. (INCHES)	PERMITTED (INCHES)	OUTER DIAMETER (MM)	SECTION WIDTH (MM)	
4.00-8	8	TT	94	A5	131	3 ¼ I	3.00D	414	115	670
5.00-8	10	TT	111	A5	145	3.00D	3 ¼ I, 3 ¾ I	467	132	1090
18x7-8	16	TT	125	A5	145	4.33R	-	462	173	1650
6.00-9	12	TT	121	A5	145	4.00E	-	540	160	1450
21x8-9	14	TT	131	A5	131	6.00E	-	535	200	1950
6.50-10	12	TT	125	A5	131	5.00F	5.50F	588	177	1650
23x9-10	20	TT	142	A5	145	6.50F	-	595	225	2650
7.00-12	14	TT	134	A5	131	5.00S	-	672	192	2120
27x10-12	14	TT	143	A5	102	8.00G	-	690	255	2725
23x5-13	10	TT	121	A5	116	3,75P	-	635	155	1150
8.15-15	14	TT	146	A5	145	7.0	-	707	216	3000
8.25-15	16	TT	149	A5	134	6.5	7	836	234	3550



HL-30 (PNEUMATIC)

HL-30 (PNEUMATIC) delivers high maneuverability thanks to its reinforced tread block pattern. Offers high performance on the field with its strong carcass structure and reinforced bead design. Provides excellent durability feature and resistance against cuts and wears.



TIRE SIZE	PR	TT/TL	LOAD INDEX	SPEED SYMBOL	INFLATING PRESSURE (psi)	RIM		INFLATED DIMENSIONS (NO LOAD)		LOAD CAPACITY PER TIRE (KG)
						RECOM. (INCHES)	PERMITTED (INCHES)	OUTER DIAMETER (MM)	SECTION WIDTH (MM)	
16x6-8	16	TT	113	A5	145	4.33R	-	425	152	1150
4.00-8	8	TT	94	A5	131	3.25	3.00D, 3 1/4 I	414	115	670
5.00-8	10	TT	111	A5	145	3.00D	3 1/4 I, 3 3/4 I	467	132	1090
18x7-8	16	TT	125	A5	145	4.33R	-	462	173	1650
21x8-9	14	TT	131	A5	131	6.00E	-	535	200	1950
6.00-9	12	TT	121	A5	145	4.00E	-	540	160	1450
6.50-10	12	TT	125	A5	131	5.00F	5.50F	588	177	1650
23x9-10	20	TT	142	A5	145	6.50F	-	595	225	2650
7.00-12	14	TT	134	A5	131	5.00S	-	672	192	2120
27x10-12	14	TT	143	A5	102	8.00G	-	690	255	2725
23x5-(13)	10	TT	121	A5	116	3.75P	-	635	155	1450
7.50-15	14	TT	144	A5	135	6.0, 6.00S	5.5, 6.5	772	212	2800
8.15-15	14	TT	146	A5	145	7.0	-	707	216	3000
250-15	20	TT	155	A5	145	7.0, 7.5	-	735	250	3875
300-15	20	TT	164	A5	131	8.0	-	840	300	5000

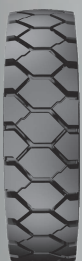

HL-40

HL-40 offers ultimate durability with its extra tread depth. Center reinforced block structure provides exceptional maneuverability especially while spot turnings. Resistant to cuts and chunking thanks to its strong carcass structure.



TIRE SIZE	PR	TT/TL	LOAD INDEX	SPEED SYMBOL	INFLATING PRESSURE (psi)	RIM		INFLATED DIMENSIONS (NO LOAD)		LOAD CAPACITY PER TIRE (KG)
						RECOM. (INCHES)	PERMITTED (INCHES)	OUTER DIAMETER (MM)	SECTION WIDTH (MM)	
6.00-9	12	TT	121	A5	145	4.00E	-	540	160	1450
6.50-10	12	TT	125	A5	131	5.00F	5.50F	588	177	1650
7.00-12	14	TT	134	A5	131	5.00S	-	672	192	2120
8.15-15	14	TT	146	A5	145	7.0	-	707	216	3000
8.25-15	16	TT	152	A5	134	6.5	7	836	234	3550



Petlas

SOLID ST (SOLID)

SOLID ST (SOLID) is developed to offer extended service life and minimized maintenance costs for forklifts operating on even surfaces. The premium rubber compound provides excellent wear behavior and extreme resistance to cuts, chips and wear. The cushion layer ensures that toughness does not lead to compromises on operator's comfort and forklift's service life. Steel bead wires embedded in the hard base compound guarantees integrity by preventing the tire from rotating on the rim.



TIRE SIZE	RECOM. (INCHES)	ETRTO		HEEL		LOAD CAPACITY (kg)										
		OUTER DIAMETER (MM)	SECTION WIDTH (MM)	NORMAL	QUICK ⁽²⁾	OUTER DIAMETER (MM)	SECTION WIDTH (MM)	FORKLIFT up to ~ 25 km/h ⁽¹⁾			TRAILER			LOAD IN DEX	SPEED INDEX	WEIGHT (kg)
								~ 6 km/h	~ 10 km/h	~ 25 km/h	~ 6 km/h	~ 10 km/h	~ 25 km/h			
6.50-10	5.00F-10	576	191	√	√	574	166	2340	1800	2340	2125	1800	128	A5	36,6	
23x10-12 ⁽³⁾	8.00G-12	583	275	√	√	581	242	3770	2900	3770	3420	2900	145	A5	49,6	

UNDER DEVELOPMENT

18x7-8

4,00-8

⁽¹⁾ Represents the maximum speed of the unladen vehicle.

⁽²⁾ It is a product with self-segmented heel structure.

⁽³⁾ The equivalent of (23) 23x10-12 in metric system is 250 / 60-12.



FLT-2 (R-3)

FLT2 (R-3) is specially designed for compactors applications. Delivers high impact resistance when used in paving applications. Offers outstanding longevity thanks to its strong carcass structure.



TIRE SIZE	PR	TT/TL	LOAD INDEX	SPEED SYMBOL	RIM		INFLATED DIMENSIONS (NO LOAD)		INFLATED DIMENSIONS (W/LOAD)		TREAD DEPTH (MM)	INFLATING PRESSURE (psi)	LOAD CAPACITY PER TIRE (KG)	
					RECOM. (INCHES)	PERMITTED (INCHES)	OUTER DIAMETER (MM)	SECTION WIDTH MIN-MAX	DYNAMIC RADIUS CIRCLE (MM)	STATIC LOADED RADIUS (MM)			Speed (KM/H)	
													40	50
23.1-26	10	TT	158	A8	DW20	-	1580	587	4582	708	27	25	4250	3870
23.1-26	12	TL	162	A8	DW20	-	1580	587	4582	708	27	28	4750	4325
23.1-26	14	TL	166	A8	DW20	-	1580	587	4582	708	27	28	5300	4825



PC-1 (C-1)

Suitable for industrial compacting roadbeds and rolling asphalt. Heat resistant smooth pattern design distributes the pressure equally on the road. Delivers high mileage performance and comfort riding.



TIRE SIZE	PR	TT/TL	LOAD INDEX	SPEED SYMBOL	RIM		INFLATED DIMENSIONS (NO LOAD)		INFLATED DIMENSIONS (W/ LOAD)		TREAD DEPTH (MM)	INFLATING PRESSURE (psi)	LOAD CAPACITY PER TIRE (KG)
					RECOM. (INCHES)	PERMITTED (INCHES)	OUTER DIAMETER (MM)	SECTION WIDTH (MM)	STATIC LOADED RADIUS (MM)	DYNAMIC RADIUS CIRCLE (MM)			
11.00-20	14	TT	165	A2	9.0,9.00V	8.0V,8.5,10.0	1048	326	476	3039	-	94	5120
13.0/80 R20	-	TL	164	A3	8.0, B8.0, 8.0V	7.33V, 7.5, B7.5, 7.5V, 8.37V	1070	291	785	3103	-	131	5000

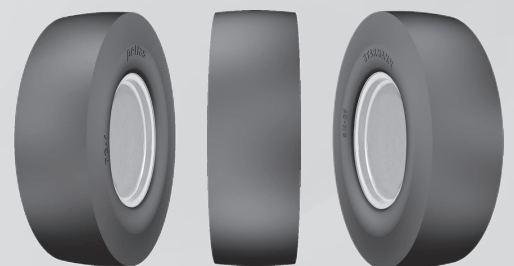

IND-15 (R-4)

Designed for general purpose use in construction applications. Delivers exceptional traction thanks to its directional pattern design and robust lugs. Strong carcass structure enhances resistance to cuts, tears and wears. Offers outstanding cost efficiency.



TIRE SIZE	PR	TT/TL	LOAD INDEX	SPEED SYMBOL	RIM		INFLATED DIMENSIONS (NO LOAD)		INFLATED DIMENSIONS (W/LOAD)		TREAD DEPTH (MM)	INFLATING PRESSURE (psi)	LOAD CAPACITY PER TIRE (KG)							
					RECOM. (INCHES)	PERMITTED (INCHES)	OUTER DIAMETER (MM)	SECTION WIDTH (MM)	DYNAMIC RADIUS CIRCLE (MM)	STATIC LOADED RADIUS (MM)			Speed (KM/H)							
													10	15	20	25	30	40	50	65
10-16,5 NHS	8	TL	131	A3	8,25	-	773	264	2242	356	17	54	2090	1950	1795	1660	1520	-	-	-
12-16,5 NHS	10	TL	142	A3	9,75	-	831	307	2410	378	19	65	2835	2650	2440	2255	2065	-	-	-



IND-35

Skid steer tire solution for harsh off-road applications. Delivers enhanced durability, traction and side impact resistance. Offers excellent performance and value by reducing operating costs.



TIRE SIZE	PR	TT/TL	LOAD INDEX	SPEED SYMBOL	RIM		INFLATED DIMENSIONS (NO LOAD)		INFLATED DIMENSIONS (W/LOAD)		TREAD DEPTH (MM)	INFLATING PRESSURE (psi)	LOAD CAPACITY PER TIRE (KG)				
					RECOM. (INCHES)	PERMITTED (INCHES)	OUTER DIAMETER (MM)	SECTION WIDTH (MM)	STATIC LOADED RADIUS (MM)	DYNAMIC RADIUS CIRCLE (MM)			Speed (KM/H)				
													10	15	20	25	30
10-16,5 NHS	12	TL	138	A3	8,25	-	799	260	365	2318	34	90	2525	2360	2170	2005	1840
12-16,5 NHS	14	TL	147	A3	9,75	-	870	307	394	2520	34	90	3290	3075	2830	2610	2400



TD-45 (F-3)

Developed for front axles of 2WD industrial tractors and compact earthmovers to be used in agricultural areas and worksites.

Ensures longevity by offering high resistance against tears and wears on hard soil, asphalt and concrete with its specially formulated tread compound and reinforced carcass structure.

It is a multi-purpose low-profile tire that can be used on trailers for both on and off road operations.



TIRE SIZE	TT/TL	LOAD INDEX	SPEED SYMBOL	RIM		INFLATED DIMENSIONS (NO LOAD)		INFLATED DIMENSIONS (W/LOAD)		INFLATING PRESSURE (psi)	LOAD CAPACITY PER TIRE (KG)	
				RECOM. (INCHES)	PERMITTED (INCHES)	OUTER DIAMETER (MM)	SECTION WIDTH (MM)	STATIC LOADED RADIUS (MM)	DYNAMIC RADIUS CIRCLE (MM)		Speed (KM/H)	
											30	40
11L-16 SL	TL	116	A8	W8L, 8LB	W10L, 10LB	800	284	371	2368	64 / 4,4	1385	1250



IND-30

IND-30 is an R-4 pattern designed to provide ultimate traction and durability for compact loaders, backhoe loaders and telehandlers. Wide and deep lugs are purposefully located to maximize traction on challenging terrains and ensure maximum durability against cuts and damages. Guarantees consistent performance throughout the tire's long lifespan with wide tread profile that improves the tire's resistance against irregular wear. The number and angles of undertread plies are specifically determined to improve lateral stability.

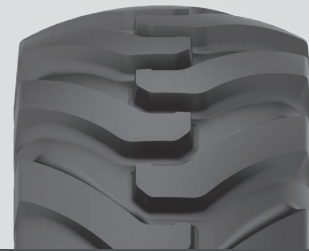

TIRE SIZE	PR	TT/TL	LOAD INDEX	SPEED SYMBOL	RIM		INFLATED DIMENSIONS (NO LOAD)		INFLATED DIMENSIONS (W/LOAD)		TREAD DEPTH (MM)	INFLATING PRESSURE (psi)	LOAD CAPACITY PER TIRE (KG)					
					RECOM. (INCHES)	PERMITTED (INCHES)	OUTER DIAMETER (MM)	SECTION WIDTH MIN-MAX	STATIC LOADED RADIUS (MM)	DYNAMIC RADIUS CIRCLE (MM)			Speed (KM/H)					
													10	15	20	25	30	40
16.0/70-20	16	TL	156	A8	13	12SDC; 13SDC; 14	1075	418	495	3103	31	58	5000	4520	4360	4240	4160	4000



IND-15 (R-4)

Designed for general purpose use in construction applications. Delivers exceptional traction thanks to its directional pattern design and robust lugs. Strong carcass structure enhances resistance to cuts, tears and wears. Offers outstanding cost efficiency.

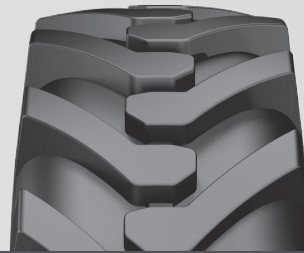

TIRE SIZE	PR	TT/TL	LOAD INDEX	SPEED SYMBOL	RIM		INFLATED DIMENSIONS (NO LOAD)		INFLATED DIMENSIONS (W/LOAD)		TREAD DEPTH (MM)	INFLATING PRESSURE (psi)	LOAD CAPACITY PER TIRE (KG)							
					RECOM. (INCHES)	PERMITTED (INCHES)	OUTER DIAMETER (MM)	SECTION WIDTH (MM)	DYNAMIC RADIUS CIRCLE (MM)	STATIC LOADED RADIUS (MM)			Speed (KM/H)							
													10	15	20	25	30	40	50	65
10.0/75-15.3	12	TL	126	A8	9.00	-	780	264	2262	355	19	68	2125	1920	1850	1800	1770	1700	-	-
11.5/80-15.3	12	TL	135	A8	9.00	-	867	290	2514	390	19	59	2725	2460	2375	2310	2265	2180	-	-
10.5/80-18	12	TL	134	A8	W9	W8; 9.00	907	274	2630	413	20	54	2650	2395	2310	2245	2205	2120	-	-
280/80-18	12	TL	134	A8	W9	W8; W10	905	282	2625	412	20	54	2650	2395	2310	2245	2205	2120	-	-
16.0/70-20	14	TL	154	A8	13	12SDC; 13SDC; 14	1097	418	3181	496	31	51	4690	4240	4090	3975	3900	3750	-	-
405/70-20	14	TL	154	A8	13	12SDC; 13SDC; 14	1097	418	3181	496	31	51	4690	4240	4090	3975	3900	3750	-	-
14.5-20	14	TT	143	D	11	11 SDC	1095	355	3176	495	28	51	4495	4085	3545	3350	3135	2890	2835	2725
16.0/70-24	14	TL	152	B	13.00	13 SDC	1178	407	3416	538	32	51	-	-	Transport	-	-	3550	-	
405/70-24	14	TL	152	B	13.00	13 SDC	1178	407	3416	538	32	51	5800	-	Loading	-	-	-	-	
480/80-26	12	TL	156	A8	DW15L	DW16L	1428	479	4141	645	27	36	5000	4520	4360	4240	4160	4000	-	-
23.1-26	14	TL	166	A8	DW20B	-	1580	587	4582	708	39	30	6560	5930	5720	5565	5460	5250	-	-



IND-25 (R-4)

Specially designed for backhoe and telehandler applications.

Offers ultimate resistance to cuts, tears, chips and chunks with its exceptional tread compound and wide lugs. Strong carcass structure ensures longevity.

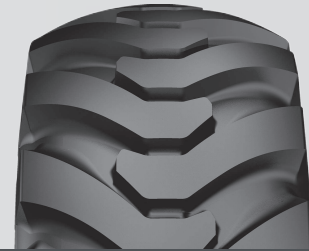

TIRE SIZE	PR	TT/TL	LOAD INDEX	SPEED SYMBOL	RIM		INFLATED DIMENSIONS (NO LOAD)		INFLATED DIMENSIONS (W/ LOAD)		TREAD DEPTH (MM)	INFLATING PRESSURE (psi)	LOAD CAPACITY PER TIRE (KG)							
					RECOM. (INCHES)	PERMITTED (INCHES)	OUTER DIAMETER (MM)	SECTION WIDTH (MM)	STATIC LOADED RADIUS (MM)	DYNAMIC RADIUS CIRCLE (MM)			Speed (KM/H)							
													10	15	20	25	30	40	50	65
12.5/80-18	14	TL	146	A8	W9	11.00	987	308	446	2862	27	62	3750	3390	3270	3180	3120	3000	2700	-
340/80-18	12	TL	142	A8	11	W10; W11	1001	343	452	2903	27	54	3315	2995	2890	2810	2755	2650	2385	-
14.5-20	14	TT	143	D	11	11 SDC	1095	355	495	3176	28	51	4495	4085	3545	3350	3135	2890	2835	2725
14.5-20	14	TL	143	D	11	11 SDC	1095	355	495	3176	28	51	4495	4085	3545	3350	3135	2890	2835	2725
16.0/70-20	14	TL	154	A8	13	12SDC; 13SDC; 14	1075	418	495	3103	33	51	4690	4240	4090	3975	3900	3750	3375	-
16.0/70-20	16	TL	156	A8	13	12SDC; 13SDC; 14	1075	418	495	3103	33	58	5000	4520	4360	4240	4160	4000	3600	-
405/70-20	14	TL	154	A8	13	12SDC; 13SDC; 14	1075	418	495	3103	33	51	4690	4240	4090	3975	3900	3750	3375	-
16.9-24	12	TL	149	A8	DW15L	DW14L	1310	429	592	3799	30	38	4065	3675	3545	3445	3380	3250	2925	-
16.9-24	14	TL	152	A8	DW15L	DW14L	1310	429	592	3799	30	43	4440	4010	3870	3760	3690	3550	3195	-
16.0/70-24	14	TL	152	B	13.00	13 (DC) - 13 (SDC)	1178	407	542	3405	34	51	-	3975	3905	3835	3765	3655	3550	-
405/70-24	14	TL	152	B	13.00	13 (DC) - 13 (SDC)	1178	407	542	3405	34	51	-	3975	3905	3835	3765	3655	3550	-
440/80-24	12	TL	149	A8	DW14L	DW13; DW13L; DW15L	1314	441	594	3810	30	38	4065	3675	3545	3445	3380	3250	2925	-
16.5/85-24	12	TL	149	A8	W13L	W15L; W14L	1322	417	597	3834	30	41	4065	3675	3545	3445	3380	3250	2925	-
16.5/85-24	16	TL	156	A8	W13L	W15L; W14L	1322	417	597	3834	30	54	5000	4520	4360	4240	4160	4000	3600	-
19.5L-24	12	TL	151	A8	DW16A	-	1314	495	594	3810	29	34	4315	3890	3760	3655	3590	3450	3105	-
16.9-28	12	TT	152	A8	DW15L	DW14L	1410	429	643	4089	30	38	4440	4012	3870	3765	3690	3550	3195	-
16.9-28	12	TL	152	A8	DW15L	DW14L	1410	429	643	4089	30	38	4440	4012	3870	3765	3690	3550	3195	-
16.9-28	14	TL	156	A8	DW15L	DW14L	1410	429	643	4089	30	44	5000	4520	4360	4240	4160	4000	3600	-
440/80-28	12	TL	152	A8	DW14L	DW13; DW13L; DW15L	1415	441	645	4104	30	38	4440	4012	3870	3765	3690	3550	3195	-
18.4-26	12	TL	156	A8	DW16L	DW15L	1425	467	644	4133	32	36	5000	4520	4360	4240	4160	4000	3600	-
18.4-26	14	TL	158	A8	DW16L	DW15L	1425	467	644	4133	32	42	5310	4800	4630	4505	4420	4250	3825	-
18.4-26	16	TL	160	A8	DW16L	DW15L	1425	467	644	4133	32	48	5625	5085	4905	4770	4680	4500	4050	-
480/80-26	14	TL	158	A8	DW15L	DW16L	1428	479	647	4141	32	42	5310	4800	4630	4505	4420	4250	3825	-



TA-60 (I-3)

TA-60 (I-3) tire designed for heavy duty tractor applications.

Reinforced carcass structure provides exceptional durability and ensures longevity. Features excellent self-cleaning properties and outstanding grip in challenging off the road conditions. The tread pattern provides excellent stability during operations.

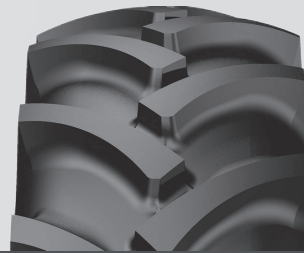

TIRE SIZE	PR	TT/TL	LOAD INDEX		SPEED SYMBOL	RIM		INFLATED DIMENSIONS (NO LOAD)		INFLATED DIMENSIONS (W/LOAD)		TREAD DEPTH (MM)	INFLATING PRESSURE (psi)	LOAD CAPACITY PER TIRE	
			FREE ROLLING (KG)	DRIVE WHEEL (KG)		RECOM. (INCHES)	PERMITTED (INCHES)	OUTER DIAMETER (MM)	SECTION WIDTH (MM)	STATIC LOADED RADIUS (MM)	DYNAMIC RADIUS CIRCLE (MM)			(FREE ROLLING SPEED, KM/H)	(DRIVE WHEEL SPEED, KM/H)
15.5/80-24 R/F	12	TL	157	145	A8	W12	W13, W14L	1262	394	573	3660	34	43	4125	2900
15.5/80-24 R/F	16	TL	163	151	A8	W12	W13, W14L	1262	394	573	3660	34	58	4875	3450



IND-5 (R-1)

Suitable for small loader, backhoe and telehandler applications. The special tread design offers exceptional traction. Offers outstanding durability thanks to its special compound.

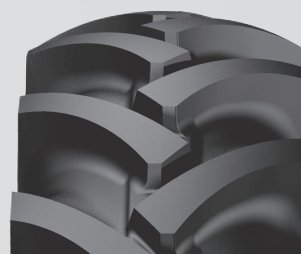

TIRE SIZE	PR	TT/TL	LOAD INDEX	SPEED SYMBOL	RIM		INFLATED DIMENSIONS (NO LOAD)		INFLATED DIMENSIONS (W/ LOAD)		TREAD DEPTH (MM)	INFLATING PRESSURE (psi)	LOAD CAPACITY PER TIRE (KG)					
					RECOM. (INCHES)	PERMITTED (INCHES)	OUTER DIAMETER (MM)	SECTION WIDTH (MM)	STATIC LOADED RADIUS (MM)	DYNAMIC RADIUS CIRCLE (MM)			Speed (KM/H)					
													10	15	20	25	30	40
18.4-26	14	TL	145	A8	W16L	W15L	1450	467	647	4321	38	40	4060	3857	3654	3451	3248	2900
16.9-30	14	TL	153	A8	W15L	W14L	1485	429	677	4307	39	42	5250	5000	4700	4450	4200	3650



PL-2 (L-2)

The ideal tire for compact machinery applications. Deep tread depth and directional tread pattern enhance traction in challenging off the road conditions. Offers excellent self-cleaning feature with its special lug design.



TIRE SIZE	PR	TT/TL	LOAD INDEX	SPEED SYMBOL	RIM		INFLATED DIMENSIONS (NO LOAD)		INFLATED DIMENSIONS (W/LOAD)		TREAD DEPTH (MM)	INFLATING PRESSURE (psi)	LOAD CAPACITY PER TIRE (KG)						
					RECOM. (INCHES)	PERMITTED (INCHES)	OUTER DIAMETER (MM)	SECTION WIDTH (MM)	STATIC LOADED RADIUS (MM)	DYNAMIC RADIUS CIRCLE (MM)			Speed (KM/H)						
													15	20	25	30	35	40	50
15.5-25	12	TL	149	B	12.00/1.3	12.00/1.3 (DC) (1)	1277	394	581	3703	25	36	3640	3575	3510	3445	3380	3350	3250



petlas

NB-38 (E-3)

NB-38 is specially developed for road construction excavators. Its aggressive tread pattern delivers outstanding traction and enables excellent self-cleaning. Promises high resistance to cuts and tears and thus, ensures longevity thanks to its reinforced carcass structure.



TIRE SIZE	PR	TT/TL	LOAD INDEX		SPEED SYMBOL	RIM		INFLATED DIMENSIONS (NO LOAD)		INFLATED DIMENSIONS (W/LOAD)		TREAD DEPTH (MM)	INFLATING PRESSURE (psi)	LOAD CAPACITY PER TIRE (SINGLE AXLE USAGE)	LOAD CAPACITY PER TIRE (DOUBLE AXLE USAGE)
			SINGLE AXE USAGE	DOUBLE AXE USAGE		RECOM. (INCHES)	PERMITTED (INCHES)	OUTER DIAMETER (MM)	SECTION WIDTH (MM)	STATIC LOADED RADIUS (MM)	DYNAMIC RADIUS CIRCLE (MM)			50	50
7.50-20	10	TT	123	122	B	5.50F	6.00F	904	214	417	2622	15	58	1550	1500
9.00-20	14	TT	140	137	B	7.00	6.5 ; 7.5	1036	230	471	3004	20	62	2500	2300
10.00-20	16	TT	146	143	B	7.50	7.0 ; 8.0	1060	270	481	3074	22	109	3000	2725



PG-200 (G-2)

Specially designed for grader and construction machinery applications. Offers excellent durability thanks to its solid tread center structure. Strong nylon carcass structure promises resistance against cuts, chunks and tears. Delivers outstanding traction in challenging conditions with its open shoulders.

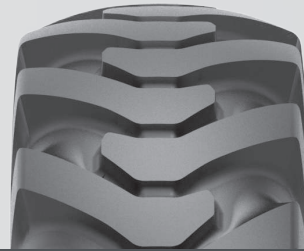

TIRE SIZE	PR	TT/TL	LOAD INDEX	SPEED SYMBOL	RIM		INFLATED DIMENSIONS (NO LOAD)		INFLATED DIMENSIONS (W/ LOAD)		TREAD DEPTH (MM)	INFLATING PRESSURE (psi)	LOAD CAPACITY PER TIRE (KG)						
					RECOM. (INCHES)	PERMITTED (INCHES)	OUTER DIAMETER (MM)	SECTION WIDTH (MM)	STATIC LOADED RADIUS (MM)	DYNAMIC RADIUS CIRCLE (MM)			Speed (KM/H)						
													15	20	25	30	35	40	50
13.00-24	12	TT	143	A8	8.00 TG SDC	9.00/1.5 (DC) (1); 10.00/VA SDC	1278	333	579	3706	25	44	3080	2970	2890	2835	2780	2725	2480
13.00-24	12	TL	143	A8	8.00 TG SDC	9.00/1.5 (DC) (1); 10.00/VA SDC	1278	333	579	3706	25	44	3080	2970	2890	2835	2780	2725	2480
14.00-24	16	TT	153	A8	8.00 TG SDC	9.00/1.5 (DC) (1); 10.00/VA SDC	1348	362	608	3909	26	54	4125	3980	3870	3800	3725	3650	3325
14.00-24	16	TL	153	A8	8.00 TG SDC	9.00/1.5 (DC) (1); 10.00/VA SDC	1348	362	608	3909	26	54	4125	3980	3870	3800	3725	3650	3325
13.00-24	16	TT	151	A8	8.00 TG SDC	9.00/1.5 (DC)- 10.00/VA SDC	1278	333	579	3706	25	58	3450	3450	3450	3450	3450	3450	3140
13.00-24	16	TL	151	A8	8.00 TG SDC	9.00/1.5 (DC)- 10.00/VA SDC	1278	333	579	3706	25	58	3450	3450	3450	3450	3450	3450	3140



PG-300 (G-2)

Designed for grader and construction machinery applications. Special tread compound increases service life and improves cut resistance. Delivers enhanced durability, traction and side impact resistance and reduces operating costs. Strengthened bead and body structure makes it suitable for being retreaded.

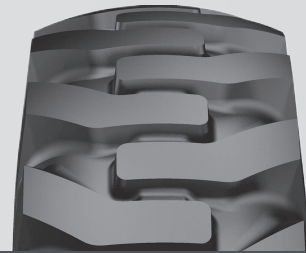

TIRE SIZE	PR	TT/TL	LOAD INDEX	SPEED SYMBOL	RIM		INFLATED DIMENSIONS (NO LOAD)		INFLATED DIMENSIONS (W/LOAD)		TREAD DEPTH (MM)	INFLATING PRESSURE (psi)	LOAD CAPACITY PER TIRE (KG)						
					RECOM. (INCHES)	PERMITTED (INCHES)	OUTER DIAMETER (MM)	SECTION WIDTH (MM)	STATIC LOADED RADIUS (MM)	DYNAMIC RADIUS CIRCLE (MM)			Speed (KM/H)						
													15	20	25	30	35	40	50
16.00-24	16	TL	160	A8	10.00VA SDC	-	1459	427	653	4231	32	47	5085	4905	4770	4680	4590	4500	4095



NB-57 (E-3)

Offers reliable performance in challenging off road conditions. Ensures resistance against chips and chunks thanks to its durable nylon carcass construction. Massive cross lugs and provides excellent traction with wide ground contact.

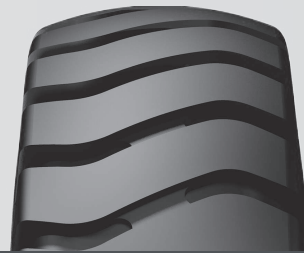

TIRE SIZE	PR	TT/TL	LOAD INDEX	SPEED SYMBOL	RIM		INFLATED DIMENSIONS (NO LOAD)		INFLATED DIMENSIONS (W/LOAD)		TREAD DEPTH (MM)	INFLATING PRESSURE (psi)	LOAD CAPACITY PER TIRE (KG)						
					RECOM. (INCHES)	PERMITTED (INCHES)	OUTER DIAMETER (MM)	SECTION WIDTH (MM)	STATIC LOADED RADIUS (MM)	DYNAMIC RADIUS CIRCLE (MM)			Speed (KM/H)						
													30	40	45	50	55	60	65
14.00-24	16	TT	153	D	10.00 VA	10.00; 9.00; 9.00V	1360	375	613	3944	24	61	4455	4345	4310	4235	4125	3945	3620
14.00-24	20	TL	157	D	10.00 VA	10.00; 9.00; 9.00V	1360	375	613	3944	24	69	5045	4920	4880	4800	4675	4470	4100
14.00-24	24	TT	160	D	10.00 VA	10.00; 9.00; 9.00V	1360	375	613	3944	24	83	5570	5435	5390	5300	5165	4940	4530
14.00-24	28	TT	168	D	10.00 VA	10.00; 9.00; 9.00V	1360	375	613	3944	24	94	6890	6720	6665	6550	6385	6105	5600
14.00-24	28	TL	168	D	10.00 VA	10.00; 9.00; 9.00V	1360	375	613	3944	24	94	6890	6720	6665	6550	6385	6105	5600
14.00-24	32	TT	170	D	10.00 VA	10.00; 9.00; 9.00V	1360	375	616	3944	24	105	7380	7200	7140	7020	6840	6540	6000
14.00-24	32	TL	170	D	10.00 VA	10.00; 9.00; 9.00V	1360	375	616	3944	24	105	7380	7200	7140	7020	6840	6540	6000



NB-60 (E-3)

Delivers outstanding grip in construction sites thanks to its non-directional tread pattern design. The tread compound improves cut and chip resistance. Offers ultimate durability thanks to solid tread center structure and strong nylon carcass.

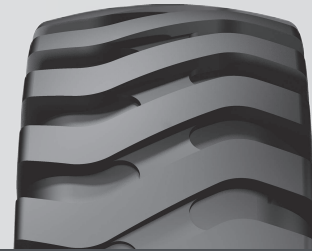

TIRE SIZE	PR	TT/TL	LOAD INDEX	SPEED SYMBOL	RIM		INFLATED DIMENSIONS (NO LOAD)		INFLATED DIMENSIONS (W/LOAD)		TREAD DEPTH (MM)	INFLATING PRESSURE (psi)	LOAD CAPACITY PER TIRE (KG)						
					RECOM. (INCHES)	PERMITTED (INCHES)	OUTER DIAMETER (MM)	SECTION WIDTH (MM)	STATIC LOADED RADIUS (MM)	DYNAMIC RADIUS CIRCLE (MM)			Speed (KM/H)						
													15	20	25	30	35	40	50
16.00-25	32	TL	177	B	11.25/2.0	11.25/2.0 IF (2); 13.00/2.0	1493	432	670	4330	31	94	8175	8030	7885	7740	7595	7520	7300
18.00-25	32	TL	183	B	13.00/2.5	13.00(2.5 IF (2); 15.00/2.5	1615	498	719	4684	34	83	9800	9625	9450	9275	9100	9015	8750
18.00-25	40	TL	187	B	13.00/2.5	13.00(2.5 IF (2); 15.00/2.5	1615	498	719	4684	34	102	10920	10725	10530	10335	10140	10045	9750
18.00-33	32	TL	188	B	13.00/2.5	-	1818	498	821	5272	37	83	11200	11000	10800	10600	10400	10300	10000



NB-57 (L-3)

Offers reliable performance in challenging off road conditions. Its durable nylon carcass construction ensures resistance against chips and chunks. Massive cross lugs and wide ground contact provides excellent traction.

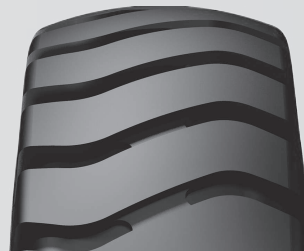

TIRE SIZE	PR	TT/ TL	LOAD INDEX	SPEED SYMBOL	RIM		INFLATED DIMENSIONS (NO LOAD)		INFLATED DIMENSIONS (W/ LOAD)		TREAD DEPTH (MM)	INFLATING PRESSURE (psi)	LOAD CAPACITY PER TIRE (KG)			LOAD CAPACITY PER TIRE (KG)		
					RECOM. (INCHES)	PERMITTED (INCHES)	OUTER DIAMETER (MM)	SECTION WIDTH (MM)	DYNAMIC RADIUS CIRCLE (MM)	STATIC LOADED RADIUS (MM)			OFF ROAD PURPOSES			HARD IMPROVED SURFACE		
													STATIC	10 KM/H	25 KM/H	STATIC	5 KM/H	10 KM/H
17.5-25	12	TL	171	A2	14.00/1.5	14.00/1.3 (1);13.00/1.4 (DC)	1348	445	3909	610	26	51	9840	6150	5230	11070	8920	8305
17.5-25	16	TT	177	A2	14.00/1.5	14.00/1.3 (1);13.00/1.4 (DC)	1348	445	3909	610	26	69	11680	7300	6205	13140	10585	9855
17.5-25	16	TL	177	A2	14.00/1.5	14.00/1.3 (1);13.00/1.4 (DC)	1348	445	3909	610	26	69	11680	7300	6205	13140	10585	9855
17.5-25	20	TL	181	A2	14.00/1.5	14.00/1.3 (1);13.00/1.4 (DC)	1348	445	3909	610	26	83	13200	8250	7015	14850	11965	11140
20.5-25	16	TL	181	A2	17.00/1.7	17.00/2.0 IF (2)	1492	520	4327	669	30	51	13200	8250	7015	14850	11965	11140
20.5-25	20	TL	186	A2	17.00/1.7	17.00/2.0 IF (2)	1492	520	4327	669	30	65	15200	9500	8075	17100	13775	12825
20.5-25	24	TL	196	A2	17.00/1.7	17.00/2.0 IF (2)	1492	520	4327	669	30	76	16480	10300	8755	18540	14935	13905
23.5-25	20	TL	191	A2	19.50/2.5	19.50/2.5 IF (2)	1617	597	4689	720	35	54	17440	10900	9265	19620	15805	14715
23.5-25	24	TL	196	A2	19.50/2.5	19.50/2.5 IF (2)	1617	597	4689	720	35	69	20000	12500	10625	22500	18125	16875



NB-60 (L-3)

Delivers outstanding grip in construction sites thanks to its non-directional tread pattern design. The tread compound ensures excellent cut and chip resistance. Provides outstanding durability thanks to its solid tread center structure and strong nylon carcass.

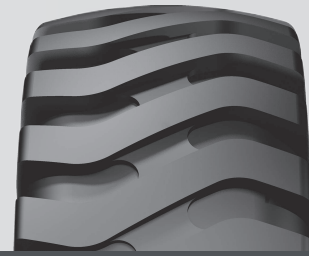

TIRE SIZE	PR	TT/TL	LOAD INDEX	SPEED SYMBOL	RIM		INFLATED DIMENSIONS (NO LOAD)		INFLATED DIMENSIONS (W/LOAD)		TREAD DEPTH (MM)	INFLATING PRESSURE (psi)	LOAD CAPACITY PER TIRE (KG)					
					RECOM. (INCHES)	PERMITTED (INCHES)	OUTER DIAMETER (MM)	SECTION WIDTH (MM)	STATIC LOADED RADIUS (MM)	DYNAMIC RADIUS CIRCLE (MM)			OFF ROAD PURPOSES			HARD IMPROVED SURFACE		
													SPEED (KM/H)					
					STATIC	10	25	STATIC	5	10								
17.5-25	16	TL	177	A2	14.00/1.5	14.00/1.3 (1); 13.00/1.4 (DC)	1348	445	610	3909	26	62	11040	6900	5865	12420	10005	9315
20.5-25	20	TL	186	A2	17.00/2.0	17.00/2.0 IF (2)	1492	520	669	4327	30	65	15200	9500	8075	17100	13775	12825
23.5-25	20	TL	191	A2	19.50/2.5	19.50/2.5 IF (2)	1617	597	720	4689	35	54	17440	10900	9265	19620	15805	14715
23.5-25	24	TL	196	A2	19.50/2.5	19.50/2.5 IF (2)	1617	597	720	4689	35	69	20000	12500	10625	22500	18125	16875
26.5-25	28	TL	203	A2	22.00/3.0	22.00/3.0 IF (2)	1750	673	775	5075	39	69	24800	15500	13175	27900	22475	20925
26.5-25	32	TL	206	A2	22.00/3.0	22.00/3.0 IF (2)	1750	673	775	5075	39	80	27200	17000	14450	30600	24650	22950
29.5-25	28	TL	207	A2	25.00/3.5	25.00/3.5 IF (2)	1873	750	825	5432	44	62	28000	17500	14875	31500	25375	23625
29.5-25	32	TL	210	A2	25.00/3.5	25.00/3.5 IF (2)	1873	750	825	5432	44	69	30400	19000	16150	34200	27550	25650



NB-70 (L-3)

Delivers optimized performance on all terrains. The special compound and aggressive design of the tread pattern enhances handling throughout its exceptionally long life. Provides outstanding resistance to cuts and wears. Specifically designed to offer ultimate performance when excellent traction is needed.



TIRE SIZE	PR	TT/ TL	LOAD INDEX	SPEED SYMBOL	RIM		INFLATED DIMENSIONS (NO LOAD)		INFLATED DIMENSIONS (W/LOAD)		TREAD DEPTH (MM)	INFLATING PRESSURE (psi)	LOAD CAPACITY PER TIRE (KG)					
					RECOM. (INCHES)	PERMITTED (INCHES)	OUTER DIAMETER (MM)	SECTION WIDTH (MM)	STATIC LOADED RADIUS (MM)	DYNAMIC RADIUS CIRCLE (MM)			OFF ROAD PURPOSES			HARD IMPROVED SURFACE		
													Speed (KM/H)					
					STATIC	10	25	STATIC	5	10								
15.5-25	12	TL	168	A2	12.00/1.3	12.00/1.3 (DC)(1)	1277	394	581	3703	25	58	8960	5600	4760	10080	8120	7560
17.5-25	16	TL	177	A2	14.00/1.5	14.00/1.3 (1); 13.00/1.4 (DC)	1348	445	610	3909	26	69	11680	7300	6205	13140	10585	9855
17.5-25	20	TL	181	A2	14.00/1.5	14.00/1.3 (1); 13.00/1.4 (DC)	1348	445	610	3909	26	83	13200	8250	7010	14850	11960	11135
20.5-25	20	TL	186	A2	17.00/2.0	17.00/2.0 IF (2)	1492	520	669	4327	30	65	15200	9500	8075	17100	13775	12825
23.5-25	20	TL	191	A2	19.50/2.5	19.50/2.5 IF (2)	1617	597	720	4689	35	54	17440	10900	9265	19620	15805	14715
23.5-25	24	TL	196	A2	19.50/2.5	19.50/2.5 IF (2)	1617	597	720	4689	35	69	20000	12500	10625	22500	18125	16875
26.5-25	28	TL	203	A2	22.00/3.0	22.00/3.0 IF (2)	1750	673	775	5075	39	69	24800	15500	13175	27900	22475	20925
26.5-25	32	TL	206	A2	22.00/3.0	22.00/3.0 IF (2)	1750	673	775	5075	39	80	27200	17000	14450	30600	24650	22950
29.5-25	28	TL	207	A2	25.00/3.5	25.00/3.5 IF (2)	1873	750	825	5432	44	62	28000	17500	14875	31500	25375	23625
29.5-25	32	TL	210	A2	25.00/3.5	25.00/3.5 IF (2)	1873	750	825	5432	44	62	30400	19000	16150	34200	27550	25650



NB-70 (L-4)

Suitable to be used in loader applications. Delivers optimized performance on all terrains. The special compound and aggressive design of the tread pattern enhances handling throughout its exceptionally long life. Provides outstanding resistance to cuts and wears. Specifically designed to offer ultimate performance when excellent traction is needed.



TIRE SIZE	PR	TT/TL	LOAD INDEX	SPEED SYMBOL	RIM		INFLATED DIMENSIONS (NO LOAD)		INFLATED DIMENSIONS (W/ LOAD)		TREAD DEPTH (MM)	INFLATING PRESSURE (psi)	LOAD CAPACITY PER TIRE (KG)			LOAD CAPACITY PER TIRE (KG)		
					RECOM. (INCHES)	PERMITTED (INCHES)	OUTER DIAMETER (MM)	SECTION WIDTH (MM)	STATIC LOADED RADIUS (MM)	DYNAMIC RADIUS CIRCLE (MM)			OFF ROAD PURPOSES			HARD IMPROVED SURFACE		
													SPEED (KM/H)					
					STATIC	10	25	STATIC	5	10								
26.5-25	32	TL	206	A2	22.00/3.0	22.00/3.0 IF (2)	1798	673	794	5214	64	80	27200	17000	14450	30600	24650	22950
29.5-25	28	TL	207	A2	25.00/3.5	25.00/3.5 IF (2)	1921	750	825	5432	69	62	28000	17500	14875	31500	25375	23625



C+CARRIER (L-4)

Specially designed for port applications. Deep and non-directional tread design delivers excellent traction and ensures long operating hours. Offers excellent durability features and high resistance against cuts, chunks and wears. Wide centerline enables riding comfort.



TIRE SIZE	PR	TT/TL	LOAD INDEX	SPEED SYMBOL	RIM		INFLATED DIMENSIONS (NO LOAD)		INFLATED DIMENSIONS (W/LOAD)		TREAD DEPTH (MM)	INFLATING PRESSURE (psi)	LOAD CAPACITY PER TIRE (KG)			LOAD CAPACITY PER TIRE (KG)		
					RECOM. (INCHES)	PERMITTED (INCHES)	OUTER DIAMETER (MM)	SECTION WIDTH (MM)	STATIC LOADED RADIUS (MM)	DYNAMIC RADIUS CIRCLE (MM)			OFF ROAD PURPOSES			HARD IMPROVED SURFACE		
													SPEED (KM/H)					
					STATIC	10	25	STATIC	5	10								
18.00-25	40	TL	206	A2	13.00/2.5	13.00(2.5 IF (2); 15.00/2.5	1673	498	743	4852	68	137	27200	17000	14450	30600	24650	22950



C+CARRIER SMOOTH (L-4S)

Smooth treaded tire for port applications. Optimized tread compound offers outstanding resistance to wear and ensures exceptional longevity. Promises high stability thanks to its smooth tread design. Highly resistant to abrasion.



TIRE SIZE	PR	TT/TL	LOAD INDEX	SPEED SYMBOL	RIM		INFLATED DIMENSIONS (NO LOAD)		INFLATED DIMENSIONS (W/LOAD)		TREAD DEPTH (MM)	INFLATING PRESSURE (psi)	LOAD CAPACITY PER TIRE (KG)			LOAD CAPACITY PER TIRE (KG)		
					RECOM. (INCHES)	PERMITTED (INCHES)	OUTER DIAMETER (MM)	SECTION WIDTH (MM)	STATIC LOADED RADIUS (MM)	DYNAMIC RADIUS CIRCLE (MM)			OFF ROAD PURPOSES			HARD IMPROVED SURFACE		
													STATIC	10	25	STATIC	5	10
18.00-25	40	TL	206	A2	13.00/2.5	13.00(2.5 IF (2); 15.00/2.5	1673	498	743	4852	62	137	27200	17000	14450	30600	24650	22950

